

RTW

Rotating Tank and Drum Washing Nozzles

DESIGN FEATURES

- Fits through a 1.77" (45mm) opening
- Low leakage, resulting in water and chemical savings, and reduction in treatment costs
- Hardened 400 series Stainless Steel bearings.

SPRAY CHARACTERISTICS

- Slow rotation speed provides better cleaning
 - Wide coverage
- Flow rates:** 19.1 to 229 l/min

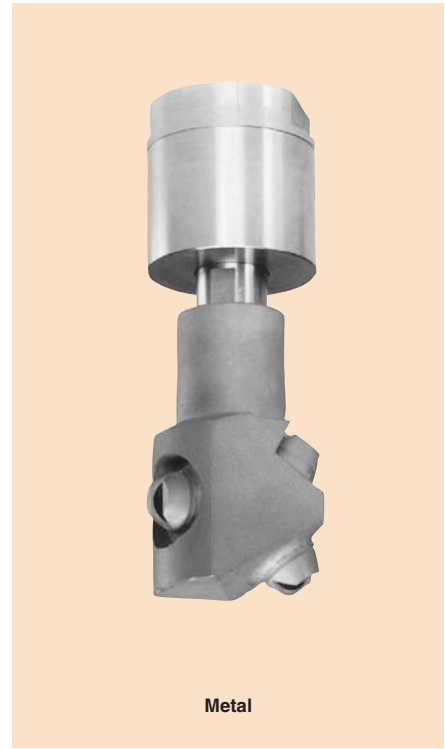

Metal

RTW Coverage Chart When spraying at 3 bar

Pipe Size	Nozzle Number	Scrubbing Diameter (mm)	Rinsing Diameter (mm)
3/4"	RTW 10	600	1800
	RTW 18	1200	2400
	RTW 21	1200	3700
	RTW 45	1800	4300

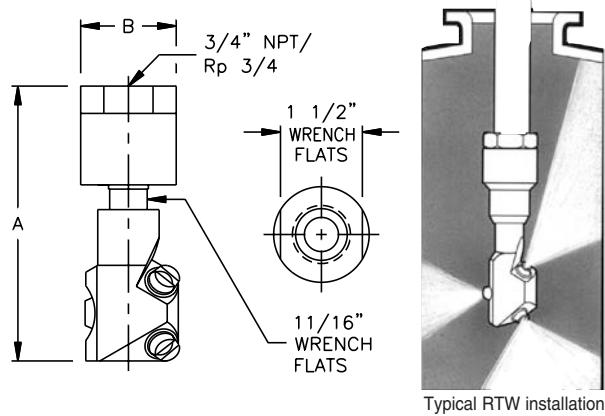

RTW Flow Rates and Dimensions Wide Spray Angle, 3/4" Pipe Size, BSP or NPT

Female Pipe Size	Nozzle Number	K Factor	LITERS PER MINUTE @ BAR						Equivalent Orifice Dia. (mm)	Approx. Dim. (mm)		Wt. (Kg)
			0.7 bar	1 bar	2 bar	3 bar	4 bar	5 bar		A	B	
3/4"	RTW10	22.8	19.1	22.8	32.2	39.5	45.6	51.0	3.96	171	44.4	0.95
	RTW18	41.0	34.3	41.0	58.0	71.0	82.0	91.7	4.72			
	RTW21	47.9	40.0	47.9	67.7	82.9	95.7	107	5.16			
	RTW45	103	86.0	103	145	178	205	229	7.54			

Flow Rate (l/min) = $K\sqrt{\text{bar}}$

Standard Materials: 316 Stainless Steel. See chart on page 21 for complete list.

SPECIAL PURPOSE

CALL 413-772-2166
For the name of your nearest BETE representative.